

**STA-RITE®**

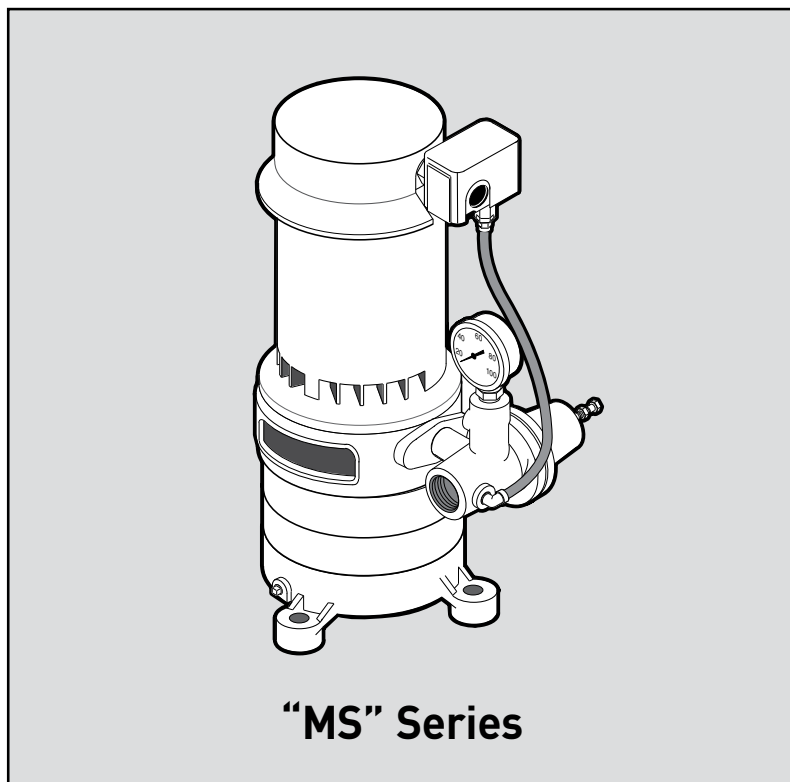

**READ AND FOLLOW  
SAFETY INSTRUCTIONS!**

**⚠** This is the safety alert symbol. When you see this symbol on your pump or in this manual, look for one of the following signal words and be alert to the potential for personal injury:

**⚠ DANGER** warns about hazards that **will** cause serious personal injury, death or major property damage if ignored.

**⚠ WARNING** warns about hazards that **can** cause serious personal injury, death or major property damage if ignored.

**⚠ CAUTION** warns about hazards that **will** or **can** cause minor personal injury or property damage if ignored.

The label **NOTICE** indicates special instructions which are important but not related to hazards.

**Carefully read and follow all safety instructions in this manual and on pump.**

Keep safety labels in good condition.

Replace missing or damaged safety labels.

Make workshops childproof; use padlocks and master switches; remove starter keys.

**California Proposition 65 Warning**

**⚠ WARNING** This product and related accessories contain chemicals known to the State of California to cause cancer, birth defects or other reproductive harm.

**ELECTRICAL SAFETY**

**⚠ WARNING** Capacitor voltage may be hazardous. To discharge motor capacitor, hold insulated handle screwdriver **BY THE HANDLE** and short capacitor terminals together. Do not touch metal screwdriver blade or capacitor terminals. If in doubt, consult a qualified electrician.

**GENERAL SAFETY**

**⚠ CAUTION** Do not touch an operating motor. Modern motors are designed to operate at high temperatures. To avoid burns when servicing pump, allow it to cool for 20 minutes after shut-down before handling.

Do not allow pump or any system component to freeze. Freezing may damage system, leading to injury or flooding. Allowing pump or system components to freeze will void warranty.

Relief valve must be capable of passing full pump flow at 75 PSI.

Pump water only with this pump.

Periodically inspect pump and system components.

Wear safety glasses at all times when working on pumps.

Keep work area clean, uncluttered and properly lighted; store properly all unused tools and equipment.

Keep visitors at a safe distance from the work areas.

**⚠ WARNING**



**Hazardous voltage. Can shock, burn, or cause death.**

Ground pump before connecting to power supply. Disconnect power before working on pump, motor or tank.

- ⚠** Wire motor for correct voltage. See "Electrical" section of this manual and motor nameplate.
- ⚠** Ground motor before connecting to power supply.
- ⚠** Meet National Electrical Code, Canadian Electrical Code, and local codes for all wiring.
- ⚠** Follow wiring instructions in this manual when connecting motor to power lines.

**⚠ WARNING**



**Hazardous pressure! Install pressure relief valve in discharge pipe.**

Release all pressure on system before working on any component.

	<b>Page</b>
General Safety .....	2
Warranty.....	3
Installation .....	4-7
Electrical.....	8-9
Operation .....	10-11
Maintenance.....	12-13
Troubleshooting.....	14
Repair Parts .....	15-16

## Limited Warranty

STA-RITE warrants to the original consumer purchaser (“Purchaser” or “You”) of the products listed below, that they will be free from defects in material and workmanship for the Warranty Period shown below.

Product	Warranty Period
Water Systems Products — jet pumps, small centrifugal pumps, submersible pumps and related accessories	<i>whichever occurs first:</i> 12 months from date of original installation, or 18 months from date of manufacture
Pro-Source™ Composite Tanks	5 years from date of original installation
Pro-Source™ Steel Pressure Tanks	5 years from date of original installation
Pro-Source™ Epoxy-Lined Tanks	3 years from date of original installation
Sump/Sewage/Effluent Products	12 months from date of original installation, or 18 months from date of manufacture

Our warranty will not apply to any product that, in our sole judgement, has been subject to negligence, misapplication, improper installation, or improper maintenance. Without limiting the foregoing, operating a three phase motor with single phase power through a phase converter will void the warranty. also that three phase motors must be protected by three-leg, ambient compensated, extra-quick trip overload relays of the recommended size or the warranty is void.

Your only remedy, and STA-RITE’s only duty, is that STA-RITE repair or replace defective products (at STA-RITE’s choice). You must pay all labor and shipping charges associated with this warranty and must request warranty service through the installing dealer as soon as a problem is discovered. No request for service will be accepted if received after the Warranty Period has expired. This warranty is not transferable.

STA-RITE SHALL NOT BE LIABLE FOR ANY CONSEQUENTIAL, INCIDENTAL, OR CONTINGENT DAMAGES WHATSOEVER. THE FOREGOING WARRANTIES ARE EXCLUSIVE AND IN LIEU OF ALL OTHER EXPRESS AND IMPLIED WARRANTIES, INCLUDING BUT NOT LIMITED TO THE IMPLIED WARRANTIES OF MERCHANTABILITY AND FITNESS FOR A PARTICULAR PURPOSE. THE FOREGOING WARRANTIES SHALL NOT EXTEND BEYOND THE DURATION EXPRESSLY PROVIDED HEREIN.

Some states do not allow the exclusion or limitation of incidental or consequential damages or limitations on the duration of an implied warranty, so the above limitations or exclusions may not apply to You. This warranty gives You specific legal rights and You may also have other rights which vary from state to state.

This Limited Warranty is effective June 1, 2011 and replaces all undated warranties and warranties dated before June 1, 2011.

### STA-RITE INDUSTRIES

293 Wright Street • Delavan, WI U.S.A. 53115

Phone: 1-888-782-7483 • Fax: 1-800-426-9446 • Web Site: [sta-rite.com](http://sta-rite.com)

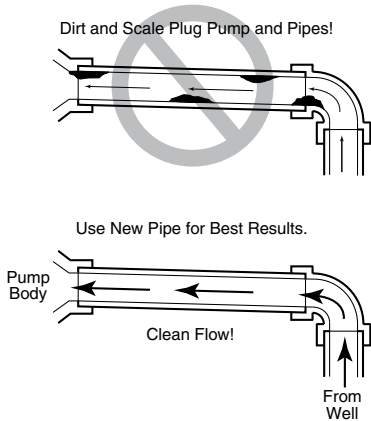

**Figure 1: No Dirt or Scale in Suction Pipe**

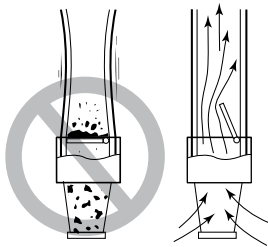

**Figure 2: Foot Valve Must Work Freely**

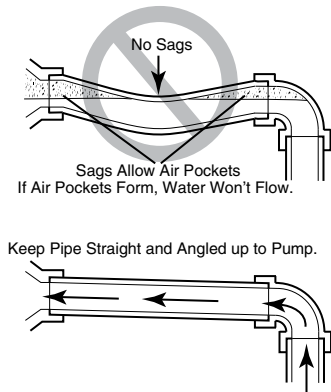

**Figure 3: No Air Pockets in Suction Pipe**

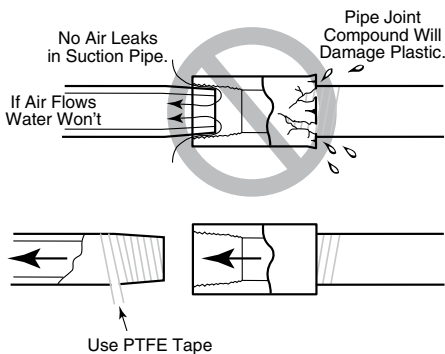

**Figure 4: Suction Pipe Must Not Leak**

## BEFORE YOU INSTALL YOUR PUMP

**NOTICE:** For proper performance, pump **MUST** be matched to ejector and to well depth. Use shallow well installation for wells up to 25 ft depth to water and deep well ejector for depths up to 130 ft.

- Step 1. Long runs and many fittings increase friction and reduce flow. Locate pump as close to well as possible: use as few elbows and fittings as possible.
- Step 2. Be sure well is clear of sand. Sand will plug the pump and void the warranty.
- Step 3. Protect pump and all piping from freezing. Freezing will split pipe, damage pump and void the warranty. Check locally for frost protection requirements (usually pipe must be 12" below frost line and pump must be insulated).
- Step 4. Be sure all pipes and foot valve are clean and in good shape.
- Step 5. No air pockets in suction pipe.
- Step 6. No leaks in suction pipe. Use PTFE pipe thread sealant tape to seal pipe joints.
- Step 7. Match pump to well.  
**IMPORTANT:** Flow into well must at least equal flow out through pump!
- Step 8. Unions installed near pump and well will aid in servicing. Leave room to use wrenches.
- Step 9. Plug 1" drive port when installing on shallow well.

## SHALLOW WELL/CENTRIFUGAL INSTALLATION

No ejector is used in this case, plug the smaller of the two inlet ports, using the larger for the suction pipe. Refer to Figure 6 for installation tips. Maximum depth to water for shallow well/centrifugal operation is 25 feet.

**NOTICE:** To avoid pump overloading and motor failure, install a flow control valve at the discharge to limit flow to 20 gallons per minute.

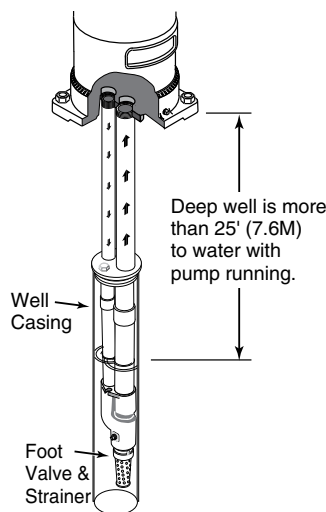

**Figure 5: Double Pipe Deep Well**

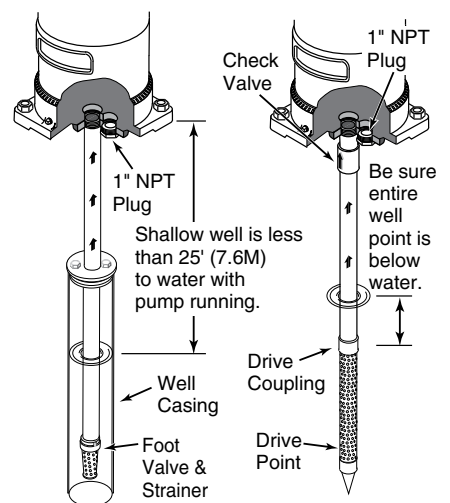

**Figure 6: Cased Shallow Well and Drive Point Shallow Well**

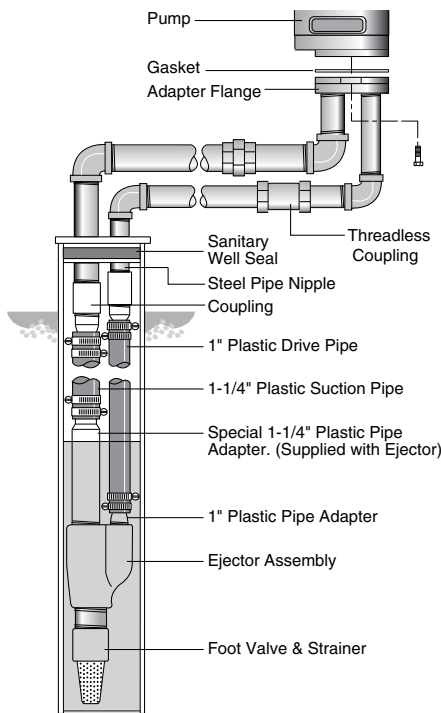

**A-OFFSET INSTALLATION  
PLASTIC PIPE SHOWN**

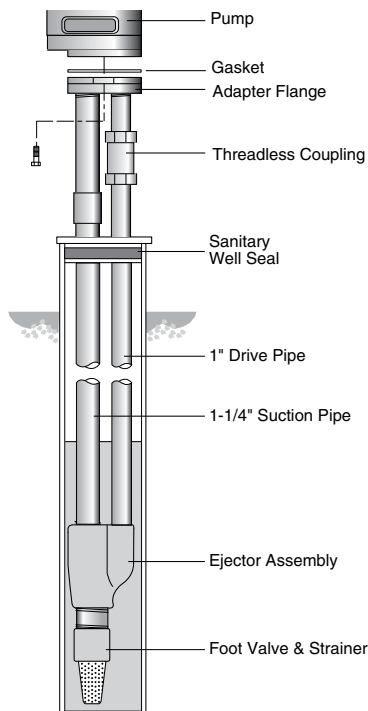

**B-OVER THE WELL INSTALLATION  
STEEL PIPE SHOWN**

**Figure 7**

**PIPING IN THE DEEP WELL**

See Figures 7 and 8.

**NOTICE:** Deep well installations are either single pipe (2" wells) or double pipe (4" and larger wells). In a double pipe installation, the larger pipe is the suction pipe and the smaller pipe is the drive pipe (very deep wells may use suction and drive pipes of the same diameter).

Plastic pipe is ideal for double pipe installations. Due to its light weight, it is easy to handle and does not usually require a block and tackle for installation and removal.

**PLASTIC PIPE INSTALLATION – DOUBLE PIPE**

**NOTICE:** Use PTFE pipe thread sealant tape on all male threads on plastic pipe and fittings to prevent air leaks in suction piping.

- Step 1. Inspect ejector to make sure that nozzle and venturi openings are clean and clear.
- Step 2. Inspect pipe for any foreign matter or obstructions.  
**IMPORTANT:** Make sure that no foreign matter enters pipe openings while installing pump.
- Step 3. Make sure foot valve operates freely: attach to ejector with a close nipple. Use PTFE pipe thread sealant tape on male threads.
- Step 4. Install nozzle and venturi in deep well ejector.
- Step 5. Using PTFE pipe thread sealant tape on male threads, install special plastic pipe adapter (supplied with ejector) by screwing adapter into 1-1/4" tapped hole in ejector body (see Figure 7A).
- Step 6. Thread a 1" plastic pipe adapter into the 1" tapped hole in ejector body (see Figure 7A).
- Step 7. Install sufficient plastic pipe in well casing to place ejector at the proper depth. (Your well driller should supply this information.)  
**IMPORTANT:** as a guide, the ejector should be set at least 10 to 20 feet below the lowest water level with pump running, if possible, but always at least five feet from the bottom of the well.
- Step 8. Tighten all hose clamps securely on plastic pipe. Use two clamps per joint to prevent air leaks into suction pipe. Clamp screws should be on opposite sides of the pipe. Fill pipes with water to make sure that foot valve and connections do not leak.
- Step 9. Install sanitary well seal on top of well casing; use steel nipple through well seal as shown in Figure 7A.  
**IMPORTANT:** align locating lugs on adapter flange and pump base so that pump discharge will be aligned with piping.
- Step 10. Install 1" nipple in one side of adapter flange. Slide threadless coupling down over drive pipe from well. Thread adapter flange onto suction pipe from well and align nipple and drive pipe.
- Step 11. Slide threadless coupling up and secure nipple to drive pipe.
- Step 12. Remove paper backing from adhesive gasket. Apply gasket to adapter flange, making sure that holes line up.
- Step 13. Align locating lugs on pump base with locating lugs on adapter flange; attach pump to flange with cap screws provided.
- Step 14. See "Discharge Pipe Sizes" for information regarding correct discharge pipe size.

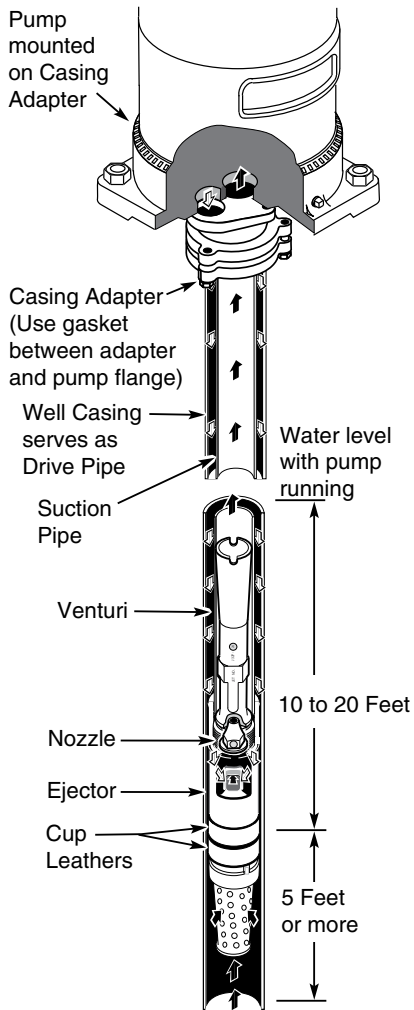

Figure 8

### SINGLE PIPE EJECTOR INSTALLATION

Single pipe installations require (see Figure 8):

- a. Galvanized steel pipe
- b. Leather packer-type ejector with built-in foot valve
- c. Turned couplings (supplied with packer-type ejector)
- d. Well casing adapter.

Step 1. Connect ejector to first length of pipe. Use pipe joint compound sparingly on male threads.

Step 2. Lower pipe into casing. Use special turned couplings (included with 2" single pipe ejector package) to increase water flow. Use pipe joint compound sparingly on male couplings threads.

**NOTICE:** Fill pipe with water as each length is added to be sure foot valve and connections do not leak.

Step 3. Add lengths of pipe until the ejector reaches the proper depth. (Your well driller should supply this information.)

**IMPORTANT:** as a guide, the ejector should be set at least 10 to 20 feet below the lowest water level with pump running, if possible, but always at least 5 feet above the bottom of the well (see Figure 8).

Step 4. To properly seat the cup seals, after the ejector is correctly positioned move the assembly up and down slightly. Water pressure in the casing will then soak the cup seals (see Figure 8). They should seal within 2-3 hours after installation.

Step 5. With ejector set, install well casing adapter. Remove pipe holder. Align locating lugs and tighten adapter to form seal with well casing.

### DISCHARGE PIPE SIZES

Step 1. If increasing discharge pipe size, install reducer in pump discharge port. Do not increase pipe size by stages.

Step 2. When the pump is set away from the points of water use, the discharge pipe size should be increased to reduce pressure losses caused by friction.

- Up to 100 ft run: Same size as pump discharge port.
- 100 ft. to 300 ft run: Increase one pipe size.
- 300 ft. to 600 ft run: Increase two pipe sizes.

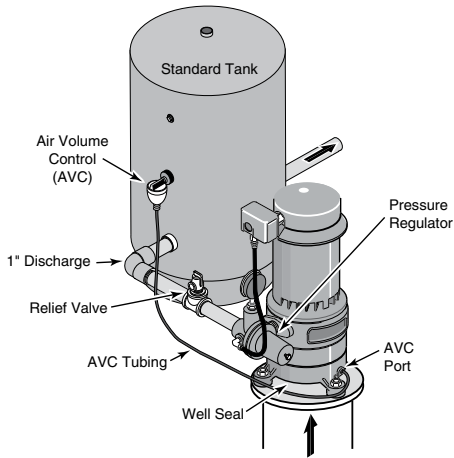

**Figure 9: Pump With Standard Tank**

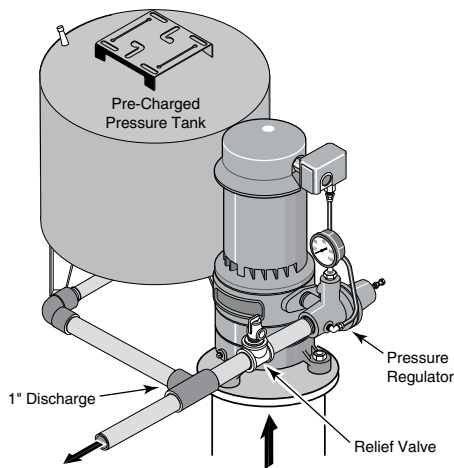

**Figure 10: Pump With Pre-charged Tank**

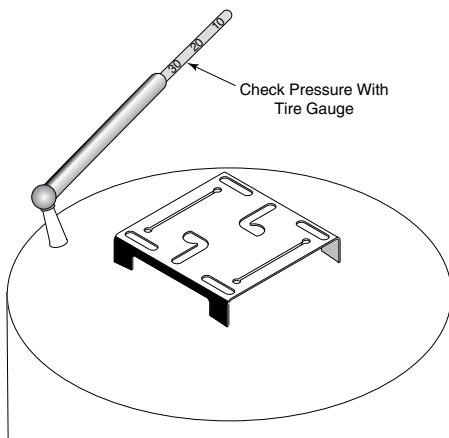

**Figure 11: Checking Tank Pre-charge**

## PRESSURE TANK INSTALLATION – DEEP WELL

The Pressure Tank provides a reservoir of water under pressure and maintains cushion of air pressure to prevent pipe hammering and possible damage to plumbing components. When water is drawn off through house fixtures, the pressure in the tank is lowered and the pressure switch starts the pump.

### STANDARD TANK CONNECTION

When a standard tank is used, an air volume control (AVC) adds air to the tank when it is needed. See Figure 10 for typical standard tank installation. To connect AVC to pump, thread a 1/4" compression fitting into tapped hole on the front of the pump. Cut tubing to length to reach AVC; assemble to fitting on pump and to AVC on tank. See installation instructions provided with tank and AVC for details.

### PRECHARGED TANK CONNECTION

When a precharged tank is used, no AVC is necessary. See Figure 10 for typical precharged tank installation. A precharged tank contains a factory provided air charge.

**IMPORTANT:** your pump pressure switch is set for a 30-50 PSI range and requires a tank pre-charge of 28 PSI for proper operation (see Fig. 11). See tank owner's air charge. An annual check on tank charge is recommended.

**⚠ CAUTION** Disconnect power before working on pump, motor, pressure switch, or wiring.

Your Motor Terminal Board (under the motor end cover) and Pressure Switch look like one of those shown below. Convert to 115 Volts as shown. Do not change motor

wiring if line voltage is 230 Volts or if you have a single voltage motor. Connect power supply as shown for your type of switch and your supply voltage.

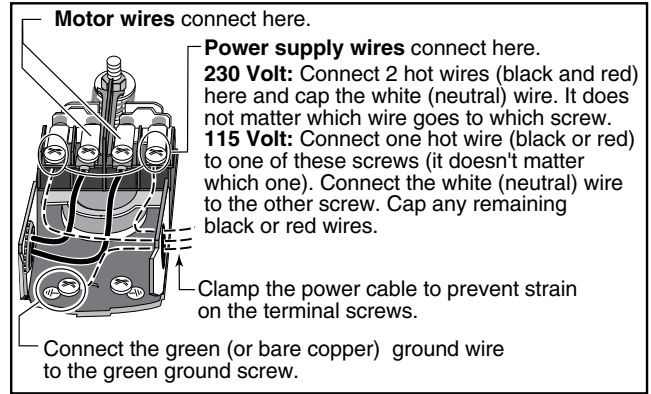
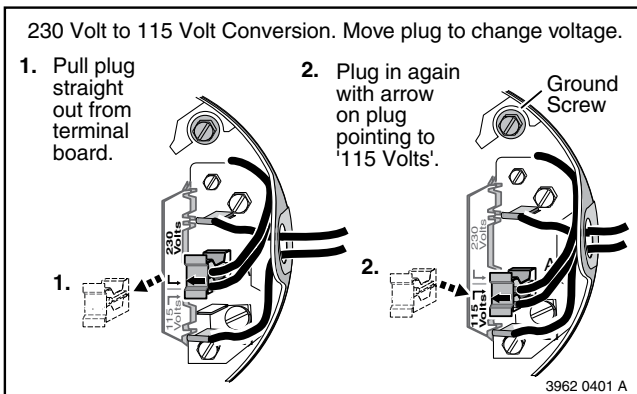
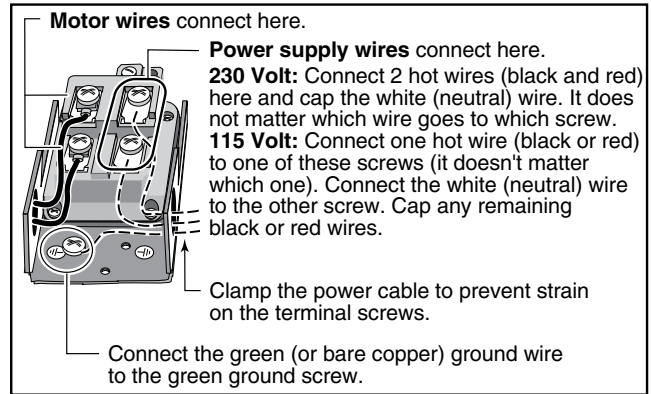
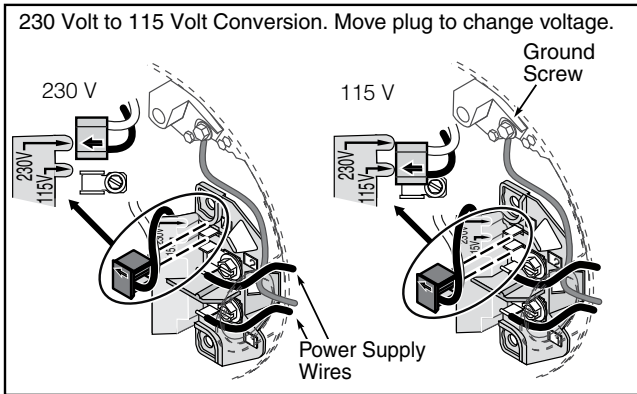

Figure 12: Motor wiring connections through Pressure Switch. Match motor voltage to line voltage.

**⚠ WARNING** Hazardous voltage. Can shock, burn, or kill. Connect ground wire before connecting power supply wires. Use the wire size (including the ground wire) specified in the wiring chart. If possible, connect the pump to a separate branch circuit with no other appliances on it.

**⚠ WARNING** Explosion hazard. Do not ground to a gas supply line.

## WIRING CONNECTIONS

**⚠ WARNING** Fire hazard. Incorrect voltage can cause a fire or seriously damage the motor and voids the warranty. The supply voltage must be within  $\pm 10\%$  of the motor nameplate voltage.

**NOTICE:** Dual-voltage motors are factory wired for 230 volts. If necessary, reconnect the motor for 115 volts, as shown. Do not alter the wiring in single voltage motors. Install, ground, wire, and maintain your pump in compliance with the National Electrical Code (NEC) or the Canadian Electrical Code (CEC), as applicable, and with all local codes and ordinances that apply. Consult your local building inspector for code information.

### Connection Procedure:

- Step 1. Connect the ground wire first as shown in Figure 12. The ground wire must be a solid copper wire at least as large as the power supply wires.
- Step 2. There must be a solid metal connection between the pressure switch and the motor for motor grounding protection. If the pressure switch is not connected to the motor, connect the green ground screw in the switch to the green ground screw under the motor end cover. Use a solid copper wire at least as large as the power supply wires.
- Step 3. Connect the ground wire to a grounded lead in a service panel, to a metal underground water pipe, to a metal well casing at least ten feet (3M) long, or to a ground electrode provided by the power company or the hydro authority.
- Step 4. Connect the power supply wires to the pressure switch as shown in Figure 12.

**WIRING CHART – Recommended Wire and Fuse Sizes**

MOTOR HP	VOLTS	MAX. LOAD AMPS	BRANCH FUSE* RATING AMPS	DISTANCE IN FEET FROM MOTOR TO METER			
				0 TO 50	51 TO 100	101 TO 200	201 TO 300
1/2	115	13.0	20	12	12	10	8
1/2	230	6.5	15	14	14	14	14
3/4	115	14.8	20	12	12	8	6
3/4	230	7.4	15	14	14	14	14
1	115	19.2	25	10	10	8	6
1	230	9.6	15	14	14	14	12
1-1/2	230	12.0	15	14	14	14	12
2	230	11.5	15	14	14	14	12

(\*)Time delay fuse or circuit breakers are recommended in any motor circuit.

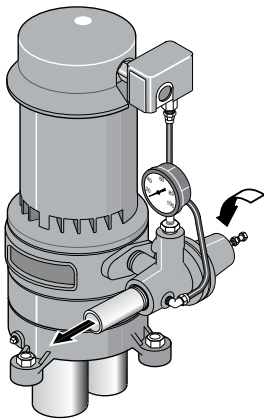

Figure 13A: Close Regulator

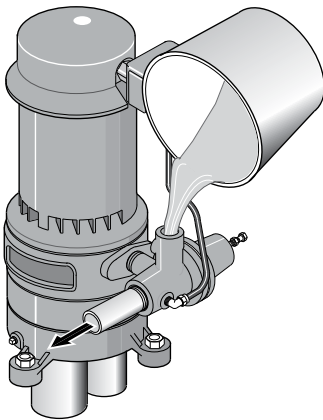

Figure 13B: Fill Pump with Water



Figure 13C: Start Pump

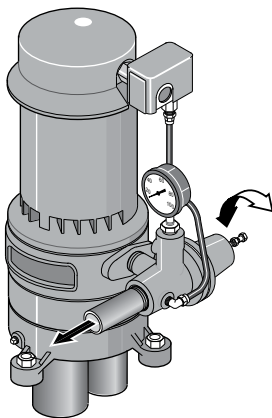

Figure 13D: Adjustor Regulator

## PRIMING THE PUMP

**CAUTION** NEVER run pump dry. Running pump without water may cause pump to overheat, damaging seal and possibly causing burns to persons handling pump. Fill pump with water before starting.

**CAUTION** NEVER run pump against closed discharge, to do so can boil water inside pump, causing hazardous pressure in unit and possibly scalding persons handling pump.

**NOTICE:** Open water system faucets before priming pump for the first time.

Step 1. Remove pressure gauge.

- a. Close regulator valve (turn clockwise - see Figure 13).
- b. Fill pump and suction pipe with water (Figure 13).
- c. Replace pressure gauge, using PTFE pipe thread sealant tape on thread; tighten gauge.

**IMPORTANT:** If a priming tee and plug have been provided for a long horizontal run, be sure to fill suction pipe through this tee and replace plug. (Do not forget to PTFE pipe thread sealant tape the plug.)

Step 2. Start Pump:

Pressure should build rapidly to 50 pounds per square inch or more as ejector and pump prime.

IF NO PRESSURE OR NO WATER, REPEAT Step No. 1 (above) two or three times to remove entrapped air from the suction pipes.

Step 3. If, after priming pump several times, no water is pumped, check the following:

- a. Suction pipe in the water and has no leaks.
 

**NOTICE:** Air can leak in even where water won't leak out. Make sure all joints are tight.
- b. Control valve, check valve, or foot valve installed and operating correctly.
- c. Pump trying to lift water more than 25 feet (shallow well) or more than rated lift for deep well ejector used (including compensation for horizontal offset).
- d. Be sure pump is not air locked. In offset installations, pump suction port should be highest point in suction pipe; there should be no sags in suction pipe (run it straight and at a slight angle upward from well head to pump).

**NOTICE:** For deep well installation, go to Step 4 (Page 11). Shallow well installations go to Step 6 (Page 11).

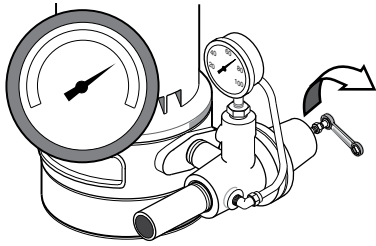

**Figure 14A: Open Regulator Valve**

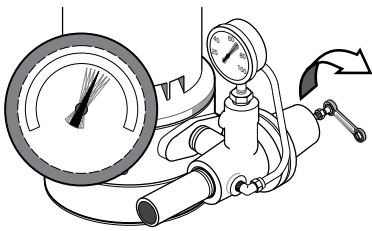

**Figure 14B: Watch for Pressure Gauge to Flutter**

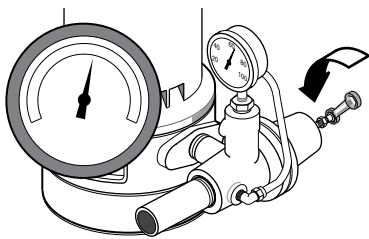

**Figure 14C: Close Regulator Valve until Pressure Stabilizes**

Step 4. Once unit has primed and pressure stabilized, slowly open (turn counterclockwise - Figure 14A) regulator valve until pressure falters (pressure gauge needle flutters; pump may become noisy - see Figure 14B). At this point, close (turn clockwise) regulator valve slightly until pressure stabilizes. This setting provides maximum flow (Figure 14C).

Step 5. Pump may draw well down far enough at this point to lose its prime. If so, close regulator valve until pressure is stable throughout pumping cycle. Close faucets and allow pump to pressurize tank and shut off.

Step 6. Check system by alternately opening and closing faucets in the system. With faucets open, pressure will drop until pump starts; with faucets closed, pressure will build up until pump shuts off.

Step 7. There are conditions of deep well operation when the regulator valve may be completely open without any faltering of pressure. In this case, operate pump with regulator valve open.

## HOW TO HANDLE A GASEOUS WELL

In some areas well water contains gases which must be allowed to escape before the water is used. To deliver gas-free water suspend a pipe, closed at the bottom and open at the top, so that it surrounds the suction pipe inlet. (See Figure 15). Since the gases rise in the well casing, the water sucked down through the pipe and into the suction pump is free of gas. This type of well must be vented to the outside of any enclosure.

## AIR CONTROL IN FLOWING WELLS

Flowing wells or wells with little or no drawdown, could create a special problem in air control in the operation of your standard tank system. In such cases, a pre-charged tank (which needs no air control) is recommended.

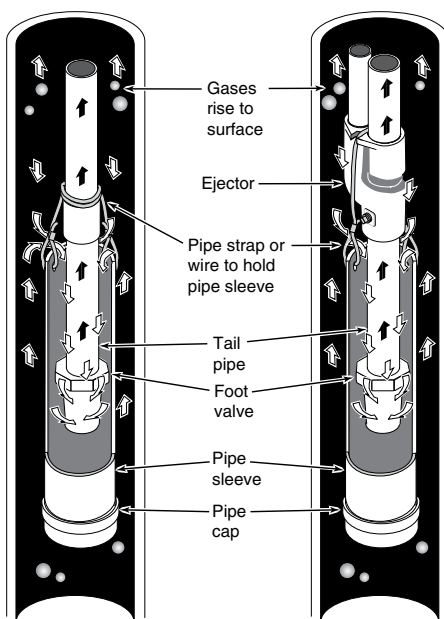

**Figure 15: Gas/Air Control in Well**

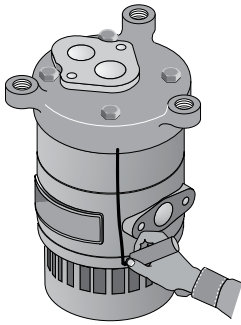

Figure 16

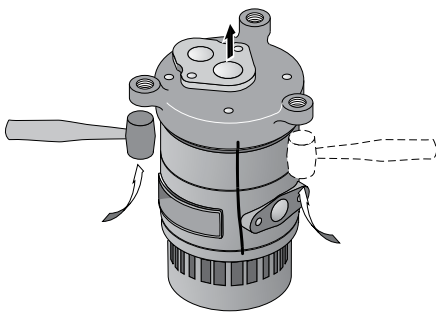

Figure 17

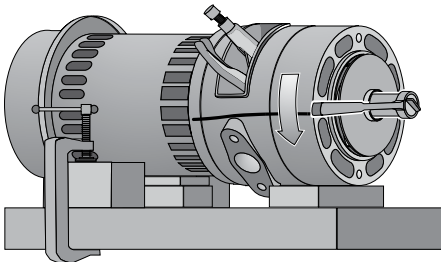

Figure 18

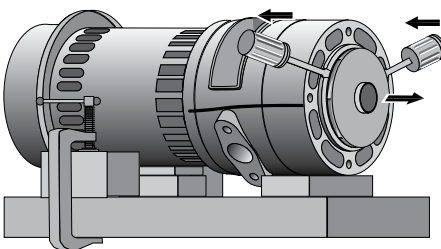

Figure 19

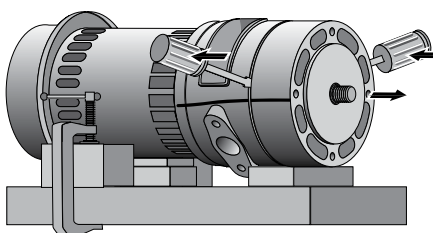

Figure 20

### PUMP DISASSEMBLY/ASSEMBLY

- Step 1. Pull disconnect switch. Disconnect power lines from pressure switch.
- Step 2. Remove the two cap screws holding the pump to the flange adapter. Do not disturb the piping in the well.
- Step 3. Remove the flange adapter gasket and scrape the surfaces clean.
- Step 4. Leaving the tubing in place, unscrew and remove the straight barbed fitting at the pressure switch.
- Step 5. Draw a line down the side of the pump with a marker to help alignment during reassembly. Mark the pump from the motor to the base volute (see Figure 16).
- Step 6. Turn the pump upside down on the bench and block it. Remove the four cap screws from the base. With a mallet, tap upward on the base to loosen it. Lift the base off of the intermediate volute (see Figure 17).
- Step 7. To reduce the chance of dropping the pump onto your foot, lay it down on the bench; block it so it won't roll.
- Step 8. Hold the motor shaft with pliers or vice grips through the opening in the pump adapter. Unscrew the impeller nut off the end of the shaft (see Figure 18).
- Step 9. The impellers are keyed to the shaft and do not unscrew. Insert two screw drivers on opposite sides under the exposed impeller and pry the impeller off (Figure 19) to remove it.
- Step 10. Carefully tap a small screwdriver or thin bladed chisel in between the intermediate volute and the pump adapter in two or three places around the pump to separate the castings (Figure 20). *Do not mar the sealing surfaces; do not break pieces out of the adapter or volute – the castings are easily damaged.*
- Step 11. Remove the intermediate volute and slide the impeller spacer off of the shaft.
- Step 12. Remove the impeller. Do not disturb the shaft keys if you are only replacing the seal.
- Step 13. Rotate the seal spring retainer cup so that the slot lines up with the shaft keys; remove the cup and spring.
- Step 14. Remove the two cap screws holding the adapter bracket to the motor.
- Step 15. With two screwdrivers on opposite sides of the pump, carefully pry the pump adapter away from the motor. This will pull the seal off of the motor shaft. *Use caution to make sure that the ceramic seal does not dig into the shaft and scratch the shaft's sealing surface.*

### INSTALLATION OF NEW SEAL

- Step 1. Clean all gasket surfaces thoroughly before reassembly. Clean the seal bore cavity in the pump adapter.
- Step 2. Wet the rubber seat ring with soapy water and push the stationary part of the seal into the seal bore cavity. Use a piece of 1" pipe pressing on a cardboard washer (to prevent damaging seal surface) as a press. *Make sure that the seal half is fully seated in the seal bore cavity.* Remove the cardboard once the seal is in place.

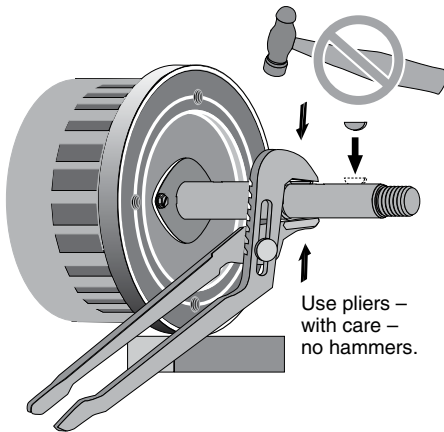

Figure 21

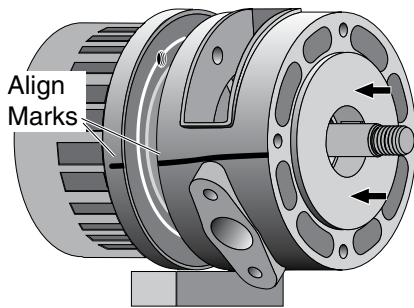

Figure 22

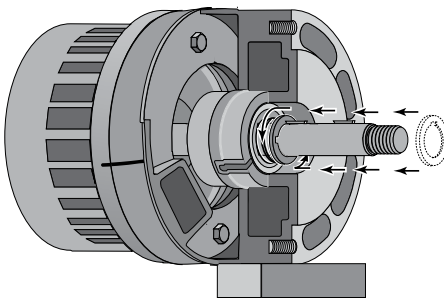

Figure 23

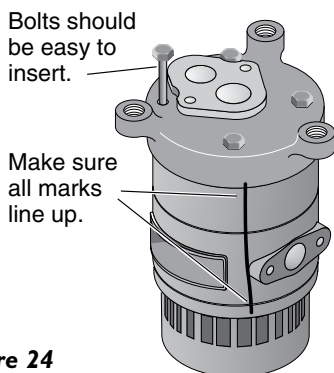
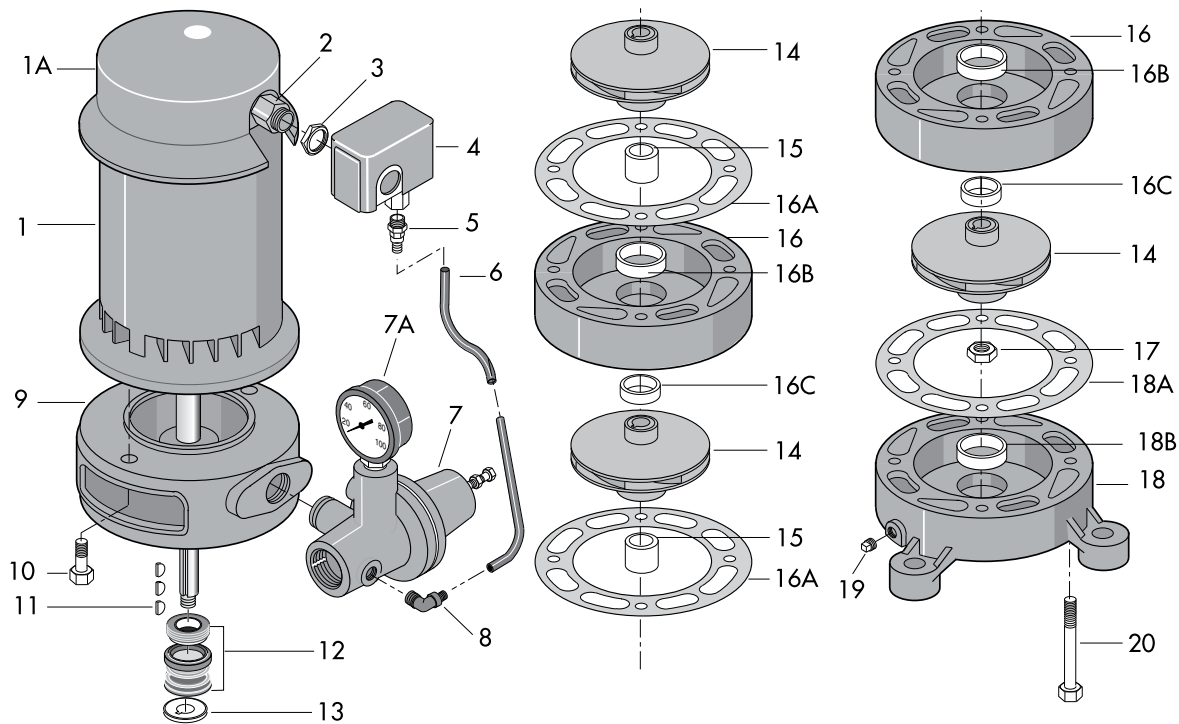

Figure 24

- Step 3. Make sure that the shaft keys are in place on the shaft. If they are not, squeeze them in place now with slip joint pliers. *Do not tap them or hit them with a hammer; you could bend the shaft* (see Figure 21). When the keys are correctly installed, the adapter will pass over the keys without interference.
- Step 4. *Carefully* slide the adapter over the shaft (see Figure 22). Do not damage the shaft sealing surface; it is highly polished and any slight scratches or nicks will ruin it.
- Step 5. Using the alignment marks made before disassembly, line up the adapter with the motor and bolt the adapter in place. Tighten the cap screws evenly.
- Step 6. Push the shaft seal and seal spring onto the shaft, after making sure that the seal faces and shaft are clean. *Take care that the shaft shoulder does not damage the carbon seal face*. Follow the seal spring with the spring holder; compress the spring and give the spring holder a quarter turn to lock it under the first shaft key (see Figure 23).
- Step 7. Slide the first impeller onto the shaft; follow it with the impeller spacer. Twist the impeller on the shaft to make sure that the shaft key is still in place and the impeller is locked to the shaft (the shaft should turn with the impeller).
- Step 8. Install a new volute gasket, lining up the bolt holes with the bolt holes in the adapter. *Make sure the gasket is right side up so that the water passage holes line up with the water passages in the volutes*.
- Step 9. Install the intermediate volute, aligning it with the mark made before disassembly. Use the long cap screws to check this alignment. *It cannot be stressed too strongly that all bolt holes and water passages of all gaskets and volutes MUST line up with each other, or the pump will not be assembled correctly*.
- Step 10. Make sure the second shaft key is in place and install the second impeller. Twist the impeller to make sure that the shaft key is still in place. Hold the motor shaft with slip-joint pliers or vice-grips and install and tighten the impeller locknut. Tightening the lock nut automatically spaces the impeller correctly. *Do not overtighten*.
- Step 11. Install the base volute gasket. *Make sure the gasket is right side up so that the water passage holes line up with the water passages in the volutes*. Install the base volute, using the alignment marks made before disassembly. Make sure that the pump discharge will correctly meet the piping when the pump is reinstalled.
- Step 12. Insert the four base capscrews and tighten evenly (see Figure 24). These should be easy to install if everything is correctly aligned. *If not, do not force them; go back over your work and find and correct the misalignment*.
- Step 13. Reinstall the pressure switch barb fitting and pressure tube.
- Step 14. Reinstall the pump on the adapter flange (use a new gasket) and reconnect the wiring and grounding. Pump is now ready for operation.

SYMPTOM	POSSIBLE CAUSE(S)	CORRECTIVE ACTION
Motor will not run	<p>Disconnect switch is off Fuse is blown or circuit breaker tripped Starting switch is defective Wires at motor are loose, disconnected, or wired incorrectly</p> <p>Pressure switch contacts are dirty</p>	<p>Be sure switch is on. Replace fuse or reset circuit breaker. DISCONNECT POWER; Replace starting switch. Refer to instructions on wiring (Page 8). DISCONNECT POWER; check and tighten all wiring.</p> <p><b>⚠ WARNING</b> Capacitor voltage may be hazardous. To discharge capacitor, hold insulated handle screwdriver BY THE HANDLE and short capacitor terminals together. Do not touch metal screwdriver blade or capacitor terminals. If in doubt, consult a qualified electrician. DISCONNECT POWER and file contacts with emery board or nail file.</p>
Motor runs hot and overload kicks off	<p>Motor is wired incorrectly Voltage is too low</p> <p>Pump cycles too frequently</p>	<p>Refer to instructions on wiring. Check with power company. Install heavier wiring if wire size is too small (See Electrical / Wiring Chart). See section below on too frequent cycling.</p>
<p>Motor runs but no water is delivered*</p> <p>* (NOTICE: <i>Stop pump</i>; then check prime before looking for other causes. Unscrew priming plug and see if water is in priming hole).</p>	<p>Pump in new installation did not pick up prime through:</p> <ol style="list-style-type: none"> <li>1. Improper priming</li> <li>2. Air leaks</li> <li>3. Leaking foot valve or check valve</li> </ol> <p>Pump has lost prime through:</p> <ol style="list-style-type: none"> <li>1. Air leaks</li> <li>2. Water level below suction pipe inlet</li> </ol> <p>Foot valve or strainer is plugged Ejector or impeller is plugged Check valve or foot valve is stuck shut Pipes are frozen Foot valve and/or strainer are buried in sand or mud</p>	<p>In new installation:</p> <ol style="list-style-type: none"> <li>1. Re-prime according to instructions.</li> <li>2. Check all connections on suction line, AVC, and ejector with soapy water or shaving cream.</li> <li>3. Replace foot valve or check valve.</li> </ol> <p>In installation already in use:</p> <ol style="list-style-type: none"> <li>1. Check all connections on suction line and shaft seal.</li> <li>2. Lower suction line into water and re-prime. If receding water level in well exceeds 25' (7.6M), a deep well pump is needed.</li> </ol> <p>Clean foot valve or strainer. Clean ejector or impeller. Replace check valve or foot valve. Thaw pipes. Bury pipes below frost line. Heat pit or pump house. Raise foot valve and/or strainer above bottom of water source. Clean foot valve and strainer.</p>
Pump does not deliver water to full capacity (Also check point 3 immediately above)	<p>Water level in well is lower than estimated Steel piping (if used) is corroded or limed, causing excess friction Offset piping is too small in size</p>	<p>A deep well jet will be needed if your well is more than 25' (7.6M) depth to water. Replace with plastic pipe where possible, otherwise with new steel pipe. Use larger offset piping.</p>
Pump delivers water but does not shut off or pump cycles too frequently	<p>Pressure switch is out of adjustment or contacts are welded together Faucets have been left open Venturi, nozzle or impeller is clogged Water level in well is lower than estimated Standard pressure tank is waterlogged and has no air cushion Pipes leak Foot valves leak Pressure switch is out of adjustment Air charge too low in pre-charged tank</p>	<p>DISCONNECT POWER; adjust or replace pressure switch.</p> <p>Close faucets. Clean venturi, nozzle or impeller. Check possibility of using a deep well jet pump</p> <p>Drain tank to air volume control port. Check AVC for defects. Check all connections for air leaks. Check connections. Replace foot valve. Adjust or replace pressure switch DISCONNECT POWER and open faucets until all pressure is relieved. Using tire pressure gauge, check air pressure in tank at valve stem located on the tank. If less than pressure switch cut-in setting (30-50 PSI), pump air into tank from outside source until air pressure is 2 PSI less than cut-in setting of switch. Check air valve for leaks (use soapy solution) and replace core if necessary.</p>
Air spurts from faucets	<p>Pump is picking up prime Leak in suction side of pump Well is gaseous Intermittent over-pumping of well. (Water drawn down below foot valve.)</p>	<p>When pump has picked up prime, it should pump solid water with no air. Suction pipe is sucking air. Check joints for leaks with soapy water. Consult factory about installing a sleeve in the well Lower foot valve if possible, otherwise restrict pump discharge</p>



## Repair Parts – Multi-Stage Jet

Key No.	Part Description	With Kit	No. Used	MSC-7 1/2 HP	MSD-7 3/4 HP	MSE-7 1 HP	MSF-7 1-1/2 HP	MSG-7 2 HP
1	Motor-115/230V Single Phase		1	A300CH	A300DH	A300EH		
1	Motor-230V Single Phase		1				A300FH	AE300GH
1A	Motor Canopy		1	U18-1300	U18-1300	U18-1300	U18-1355	U18-1355
2	Connector		1	J43-13C	J43-13C	J43-13C	J43-13C	J43-13C
3	Locknut - 1/2"		1	U36-112ZP	U36-112ZP	U36-112ZP	U36-112ZP	U36-112ZP
4	Pressure Switch		1	U217-1216	U217-1216	U217-1216	U217-204E	U217-204E
5	Barbed Fitting - Straight		1	U111-211T	U111-211T	U111-211T	U111-211T	U111-211T
6	Switch Tube - 14-1/2"		1	U37-672P	U37-672P	U37-672P	U37-672P	U37-672P
7	Pressure Regulator Assembly		1	J212-24E	J212-24E	J212-24E	J212-24E	J212-24E
7A	Pressure Gauge		1	U239-3	U239-3	U239-3	U239-8	U239-8
8	Barbed Fitting - Elbow		1	U111-212T	U111-212T	U111-212T	U111-212T	U111-212T
9	Adapter (-6 Series)		1	L2-16	L2-16	L2-16	L2-16	L2-16
9	Adapter (-7 Series)		1	L2-16A	L2-16A	L2-16A	L2-16A	L2-16A
10	Capscrew - 3/8"-16x1-1/4" Lg.		2	U30-75ZP	U30-75ZP	U30-75ZP	U30-75ZP	U30-75ZP
11	Shaft Key	OH/SG	2	U65-15SS	U65-15SS	U65-15SS	U65-15SS(3)	U65-15SS(3)
12	Shaft Seal (-6 Series)	OH/SG	1	U109-99	U109-99	U109-99	U109-99	U109-99
12	Shaft Seal (-7 Series)	OH/SG	1	17351-0101A	17351-0101A	17351-0101A	17351-0101A	17351-0101A
13	Spring Holder	OH/SG	1	J24-11	J24-11	J24-11	J24-11	J24-11
14	Impeller	OH	2	J105-75PA	J105-75P	J105-76P	J105-74PA(3)	J105-74P(3)
15	Spacer - Impeller (1 or 2 required)		-	J43-23	J43-23	J43-23	J43-23	J43-23
16	Intermediate Volute w/Wear Rings & Gasket		(1)	J101-26	J101-26	J101-26	J101-26(2)	J101-26(2)
16A	Gasket	OH/SG	(1)	J20-11	J20-11	J20-11	J20-11	J20-11
16B	Wear Ring	OH	(1)	J23-10	J23-10	J23-10	J23-10	J23-10
16C	Wear Ring	OH	(1)	J23-11	J23-11	J23-11	J23-11	J23-11
17	Impeller Stop Nut		1	U36-175SSW	U36-175SSW	U36-175SSW	U36-175SSW	U36-175SSW
18	Base Volute Complete		1	J101-33	J101-33	J101-33	J101-33A	J101-33A
18A	Gasket	OH/SG	(1)	J20-11	J20-11	J20-11	J20-11	J20-11
18B	Wear Ring	OH	(1)	J23-10	J23-10	J23-10	J23-10	J23-10
19	Pipe Plug - 1/4" NPT		(1)	U78-941ZPV	U78-941ZPV	U78-941ZPV	U78-941ZPV	U78-941ZPV
20	Capscrew - 3/8"-16x4-1/4" Lg.		(4)	U30-82ZP	U30-82ZP	U30-82ZP	-	-
20	Capscrew - 3/8"-16x6" Lg.		(4)	-	-	-	U30-81ZP	U30-81ZP
<b>SERVICE KITS</b>								
	Seal and Gasket Kit (SG)		1	PP1650	PP1650	PP1650	PP1650	PP1650
	Overhaul Kit (OH)		1	PP1655	PP1656	PP1657	PP1658	PP1659

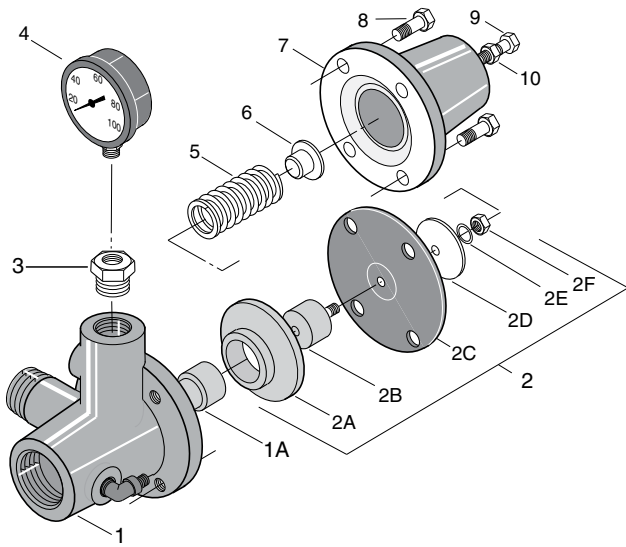

### Pressure Regulator

Key No.	Part Description	J212-24	J212-24A
1	Pressure Regulator w/Seat	J112-14	J112-14
1A	Valve Seat	J66-16	J66-16
2	Diaphragm Assembly	J220-16B	J220-16B
2A	Regulator Guide	J42-5	J42-5
2B	Stem	J62-9	J62-9
2C	Diaphragm	J20-16	J20-16
2D	Spring Follower	J43-31	J43-31
2E	Lock Washer	U43-23ZP	U43-23ZP
2F	Nut 1/4-20	U36-36ZP	U36-36ZP
3	Reducer Bushing 1/2x1/8 NPT	U78-107DT	U78-107DT
4	Pressure Gauge	*	*
5	Spring	J24-13	J24-13
6	Spring Guide	J61-5	J61-5
7	Bonnet	J52-9	J52-9
8	Capscrew 5/16-18x3/4" Lg. (4)	U30-60ZP	U30-60ZP
9	Adjusting Screw 5/16-18	U30-69FTZP	U30-69FTZP
10	Locknut 5/16-18	U36-205ZP	U36-205ZP

\* The Pressure Gauge is not supplied with the Regulator. See Page 15.

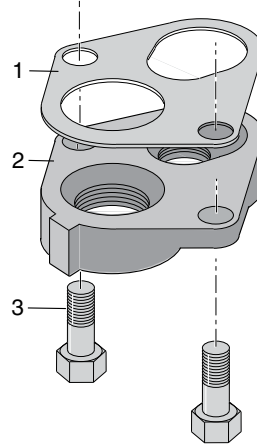

Item 1-Remove paper backing form gasket before applying.

Item 2-Align locating lug on flange with locating lug on base volute.

### Adapter Flange – (Not included with pump)

Key No.	Part Description	Qty.	J216-26 1-1/4x1	J216-27 1-1/4x1-1/4
1	Gasket	1	J20-12	J20-12
2	Adapter Flange	1	J2-15	-
3	Capscrew	2	U30-86ZP	U30-86ZP

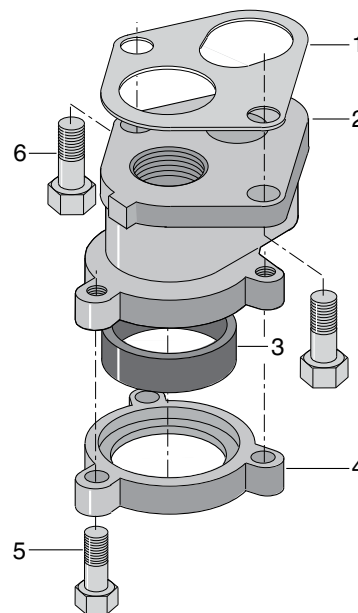

Item 1-Remove paper backing form gasket before applying.

Item 2-Align locating lug on flange with locating lug on base volute.

377 1293

### Casing Adapters – (Not included with pump)

Key No.	Part Description	Qty.	J216-21 2"	J216-22 2-1/2"	J216-23 3"
1	Gasket	1	J20-12	J20-12	J20-12
2	Adapter Body	1	J51-10	J51-9	J51-9
3	Seal Ring	1	J21-17	J21-24	J21-21
4	Lower Flange	1	J16-20ZZP	J16-30ZZP	J16-24ZZP
5	Capscrew, 3/8-16x1-1/2 Lg.	3	U30-76ZP	U30-76ZP	U30-76ZP
6	Capscrew, 1/2-13x1-1/4"	2	U30-86PS	U30-86PS	U30-86PS